

Adcor® 500S

Thick sectioned, conformable, hydro-expansive waterstop for preventing water entry through joints in concrete sub-structures.

Description

A conformable, swellable polymer/butyl rubber waterstop strip that expands in contact with water. When fully encapsulated by poured concrete, the expansive forces form a seal against concrete faces. The seal resists hydrostatic pressure, stopping water from entering sub-structures.

Adcor® is a unique product that has been specifically developed to provide higher performance than bentonite or conventional swellable rubber waterstops. Superior performance arises from:

- controlled, reproducible, volumetric expansion.
- cohesive strength maintained after volumetric expansion.
- malleable and plastic, enabling easy application to a variety of concrete profiles.

Grace can also uniquely provide continuity of swellable waterstops at construction joint/movement joint intersections. This is achieved by linking Adcor® 500S with Servitite® AT 200 co-extruded hydrophilic/PVC waterstops (see detail).

Applications

- Construction joints in in-situ concrete structures.
- Casting new concrete against existing.
- Floor slabs cast against diaphragm retaining walls, steel sheet piles and secant piled walls.
- Joints between floor slabs and pile caps.
- Pipe penetrations through floors and walls.
- Remedial 'breaking out' of concrete.

Advantages

- Controlled volumetric expansion - reduces risk of concrete spalling.
- Conformable - can be installed onto a variety of irregular substrates.
- Retains cohesive strength at both original and expanded volume.
- No need for protective steel mesh.
- Resists at least 6 bar (60 m) hydrostatic pressure.
- Volumetric expansion min 100% in cement water.
- Simple overlap jointing on site.
- Reproducible swell after wet - dry cycling.
- Contains no sodium bentonite.
- Can be easily joined to Grace PVC waterstops at movement joints.
- Unaffected by freeze/thaw cycling.

System Components

Adcor® 500S
25 mm x 20 mm waterstop strip, supplied in 5 m rolls.

Adcor® Mastic

A hydrophilic mastic for use as a bedding bead on irregular concrete surfaces prior to the application of Adcor 500S. Adcor Mastic can also be used as a stand alone hydrophilic sealant where application of Adcor 500S is impractical.

Adcor® Adhesive MS

An adhesive for gluing Adcor 500S to smooth concrete, steel and plastic substrates. Supplied in cartridges for gun application.

Pak Adhesive™

A contact adhesive for gluing Adcor 500S to smooth concrete, steel and plastic substrates. Supplied in cans for brush application.

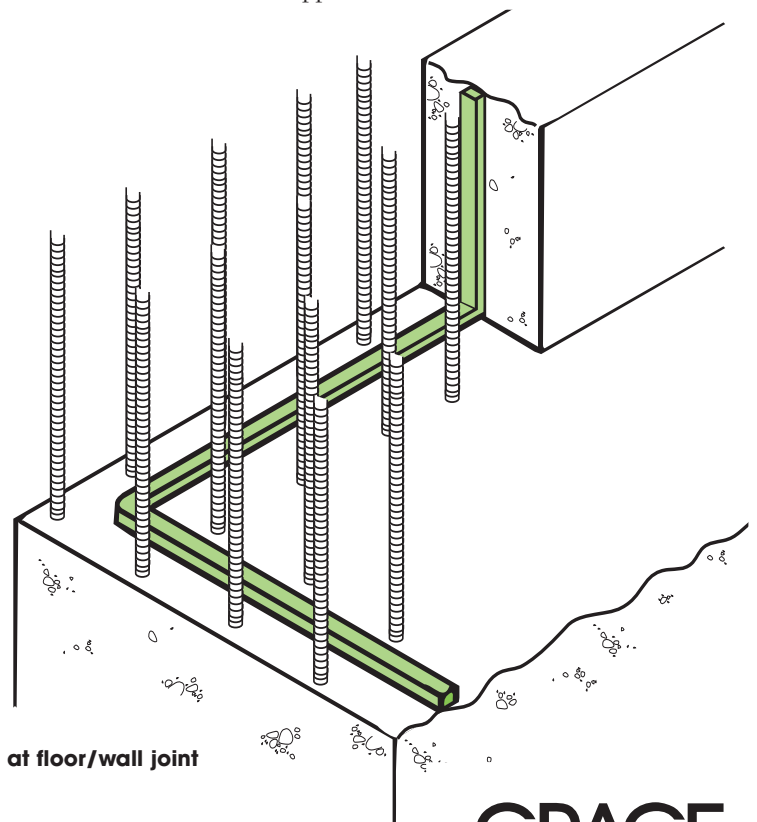

Supply

Adcor® 500S	5 m rolls 6 rolls/carton 30 cartons/pallet pallet weight 700 kg
Adcor® Mastic Adcor® Adhesive MS	310 ml cartridge 310 ml cartridge
Ancillary Products Adcor® 500S Mesh Profile Large Secura Clips	1 m strips, 30 strips/bundle Each

8. Adcor 500S can be bent around corners, however on complex geometry use Adcor Mastic as a gap filler.
9. Any damaged sections should be removed and repaired with either a new section of Adcor 500S or a 25 mm min bead of Adcor Mastic.
10. Keep Adcor 500S dry prior to pouring concrete.

Health And Safety

Adcor Mastic
Read the product label and Material Safety Data Sheet before use. Users must comply with all risk and safety phrases.

Adcor 500S

There is no legal requirement for a Material Safety Data Sheet for Adcor 500S. For health and Safety questions on this product please contact Grace.

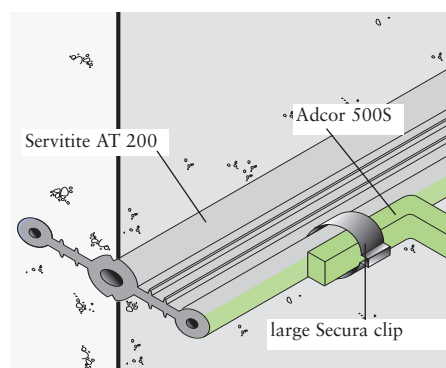

Adcor® 500S attached to Servitite® AT 200 at Movement Joint

Technical Data

	Typical Value
Profile size	25 mm x 20 mm
Colour	light blue
Volumetric expansion in cement water	min 100%
Water pressure resistance	> 6 bar (60 m)
Density	1.46 kg/cm ³
Weight	0.7 kg/m
Maximum bend	180° at 0°C
Application temperature range	-15°C to 60°C
Service temperature range	-45°C to 120°C
Minimum concrete cover	70 mm
Minimum overlap	100 mm

Limitations

Not suitable for use in movement joints (use Grace co-extruded AT System).
Not suitable for use with pre-cast concrete components.

Design

Waterstop networks must be continuous through all joints and penetrations if they are to be effective. If movement joints are necessary use Servitite® AT 200 or Serviseal® AT 240 PVC waterstops with co-extruded hydrophilic end bulbs. Adcor 500S can be easily jointed to these profiles (see detail).

Installation

1. Concrete surfaces must be clean and free of all contaminants. Remove all concrete spatter and nibs.
2. On irregular concrete faces gun a 10 mm bead of Adcor Mastic as a bedding for Adcor 500S.
3. Fix Adcor 500S using masonry nails 40 mm - 50 mm long with a washer

20 mm in diameter. Hilti EM6-20-12 FP8 shot fired fixings with 6 mm nuts and 20 mm diameter washers may also be used. Fixings should be spaced at a maximum of 300 mm centres.

4. Adcor Adhesive MS can be used on clean substrates, wire brushed to remove all dust, dirt, rust and other contaminants. The adhesive is damp surface tolerant but will not adhere to wet surfaces.

Gun a 10 mm bead onto the substrate, and press Adcor 500S firmly into place.

5. Pak Adhesive must be applied to dry substrates only. Apply by brush to both the substrate and Adcor 500S. Wait until both surfaces are dry to touch, then press Adcor 500S firmly into place.

6. At all movement joints link with Grace co-extruded AT System waterstops using Secura clips (see detail).

7. All joints should be overlapped 100 mm, ensure full contact between jointed pieces.

web Visit our web site at www.graceconstruction.com

Grace Construction Products Ltd, Ajax Avenue, Slough, Berkshire SL1 4BH United Kingdom Tel +44 (0)1753 692929 Fax +44 (0)1753 691623

Adcor, Aerofoil, BETEC, Bituthene, Hydproduct, Insupak, Korkpak, Paraflex, Paraseal, Preprufe, Procor, Servised, Servidek, Servigard, Servijoint, Servimastic, Servipak, Servirufe, Serviseal, Servistrip, Servitite, Vertigard and Vertiseal are registered trademarks of W R Grace & Co.-Conn.
Adprufe, Armourtape, Bitustik, Bitutape, Hydropaste, Pak Adhesive, PVC Edgetie, Serviband, Serviflex, Servitape, Slipstrip, and Solarshield are trademarks of W R Grace & Co.-Conn.

The information given is based on data and knowledge considered to be true and accurate and is offered for the user's consideration, investigation and verification. Since the conditions of use are beyond our control we do not warrant the results to be obtained. Please read all statements, recommendations or suggestions in conjunction with our conditions of sale including those limiting warranties and remedies which apply to all goods supplied by us. No statement, recommendation or suggestion is intended for any use which would violate or infringe statutory obligations or any rights belonging to a third party.

Copyright 2006. Grace Construction Products Limited.

Printed in England - 05.06- Ref. W0123A

GRACE
Construction Products